

© 1968 BY AMP INCORPORATED. ALL RIGHTS RESERVED. AMP PRODUCTS COVERED BY PATENTS AND/OR PATENTS PENDING.

THIS PRODUCT DESIGNED AND BUILT BY AMP INCORPORATED. NO LICENSE TO USE THAT DESIGN IN MANUFACTURE, OR TO USE ANY ISSUED OR PENDING PATENTS WHICH ARE INVOLVED, IS IMPLIED.

REVISIONS				
ZONE	LTR	DESCRIPTION	DATE	APPROVED
-	-	REF SD 24529		
A		.875 WAS .88 & .437 WAS .44	9-1-70	<i>M.K.</i>
B		ADDED NOTE 4 (SEE 4-284)	3/15/79	<i>M.K.</i>
C		REV. PER E.C.N. 8630	2-6-79	<i>M.K.</i>

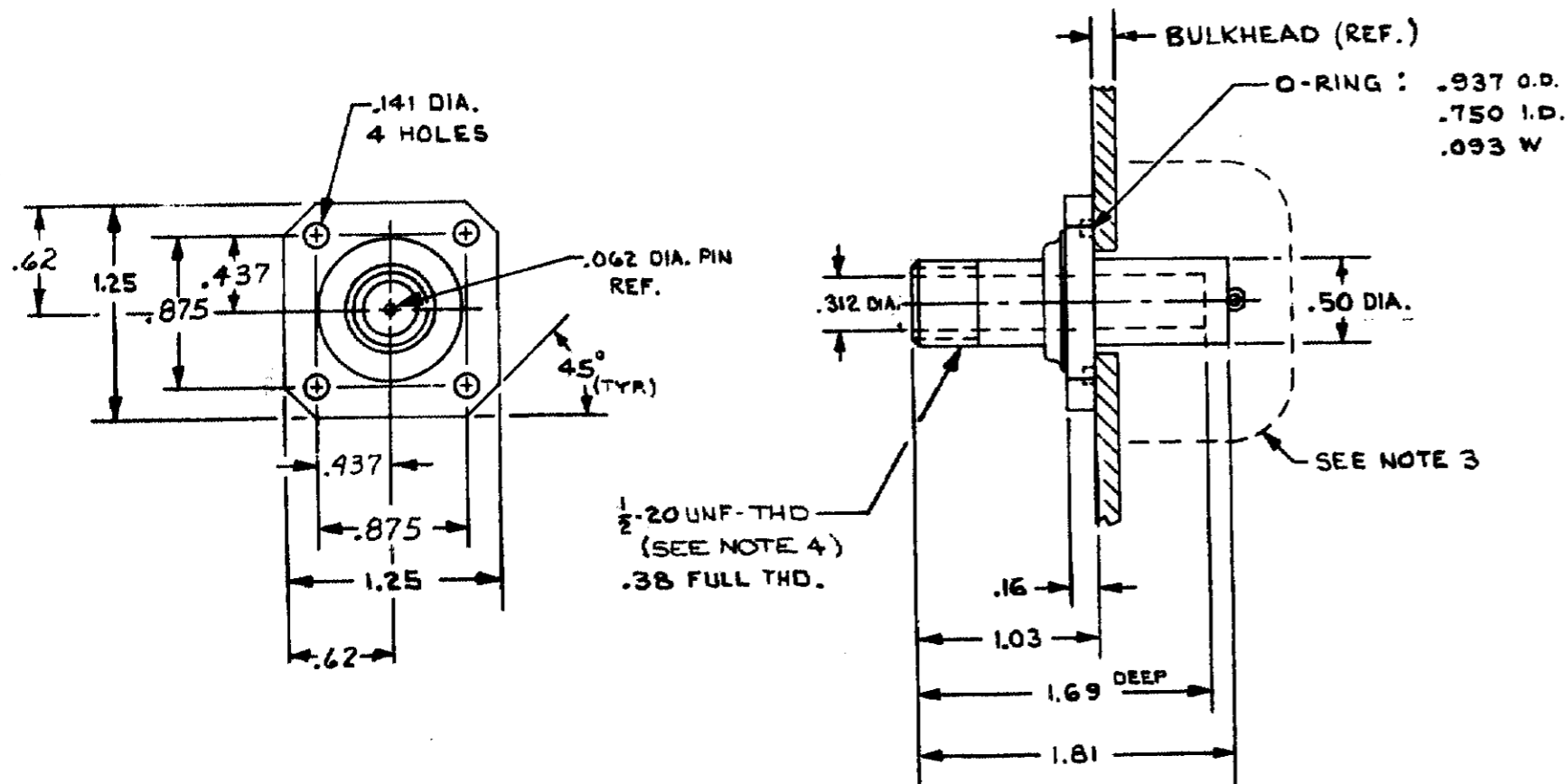

NOTE:

- RECEPTACLE TO MATE WITH AMP LGH-1L LEAD ASSEMBLY, AVAILABLE SEPARATELY. WHEN MATING LEAD ASSEMBLY WITH RECEPTACLE, APPLY SILICONE GREASE PER 830800 INSTRUCTIONS.
- ALL METAL PARTS ARE TIN PLATED.
- CUSTOMER MUST PROTECT THE RECEPTACLE BACK END AGAINST ARC OVER & BREAKDOWN
- THREAD MEASUREMENT IN ACCORDANCE WITH H-28 HANDBOOK (3 WIRE METHOD) USING WIRE DIA. .02887, MEASUREMENT OVER WIRES SHALL BE .5111/.4971 DIA.

PART NO. IS THIS DWG. -1

ITEM NO.	DWG SIZE	PART OR IDENTIFYING NO.	NOMENCLATURE OR DESCRIPTION	SYMBOL
PARTS LIST				

QTY REQD	NEXT ASSY	FINAL ASSY	NEXT ASSY	USED ON	APPLICATION

UNLESS OTHERWISE SPECIFIED:
 DIMENSIONS ARE IN INCHES
 TOLERANCES
 .00 ± .02 ANGLES ± 1°
 .000 ± .005

MATERIAL: _____

FINISH: ~

CONTRACT NO.
 DR *Overall* 2-14-68

CHK _____

APPD _____

APPD _____

DSGN APPD *J. Law* 2-14-68

OTHER APPD _____

AMP AMP INCORPORATED
 CAPITRON DIVISION
 ELIZABETHTOWN, PENNSYLVANIA

NAME
 FLANGED RECEPTACLE ASSY. WITH O-RING
 (FOR BULKHEAD APPLICATION) LGH-1L

SIZE **B** CODE IDENT NO. 00779 NUMBER 858882

SCALE N.T.S. WT SHEET 1 OF 1

PRINT DIST L-837

UN-PAID